

MODELO / MODEL		081 ECO
Dimensiones Exteriores External Dimensions	mm	790x800x1290
Dimensiones Interiores Internal Dimensions	mm	670x410x645
Tipo Abatidor Type Blast Chiller		Mixto
Capacidad GN Capacity GN	nº	8 GN1/1
Separacion entre bandejas Interstep trays	mm	65
Espesor aislamiento Thickness	mm	60
Medidas hueco puerta door opening measures	mm	670x630
Refrigerante Refrigerant	Gas	R404A
Ciclo refrigeración Chilling cycle	90' °C	+90/+3
Ciclo Congelación Freezing cycle	240' °C	+90/-18
Capacidad Abatimiento (EN17032) Chilling capacity	120' Kg	40
Capacidad Congelación (EN17032) Freezing capacity	270' Kg	24
Grupo frigorifico Refrigeration Unit	°C	Incorporado
Alimentación electrica Electric Power supply	V/~ /Hz	230/1/50
Intensidad Maxima Max. Absorbed current	A	8.9
Potencia Frigorifica Capacity refrigeration	W	1250
Potência electrica Input electric Power	W	1900
Forma entrada bandeja Input tray	mm	530
Volumen bruto exterior Total Volume external	m ³	1,23
Volumen interior neto Net Volume internal	m ³	0,173
Peso Weigh	Kg	145

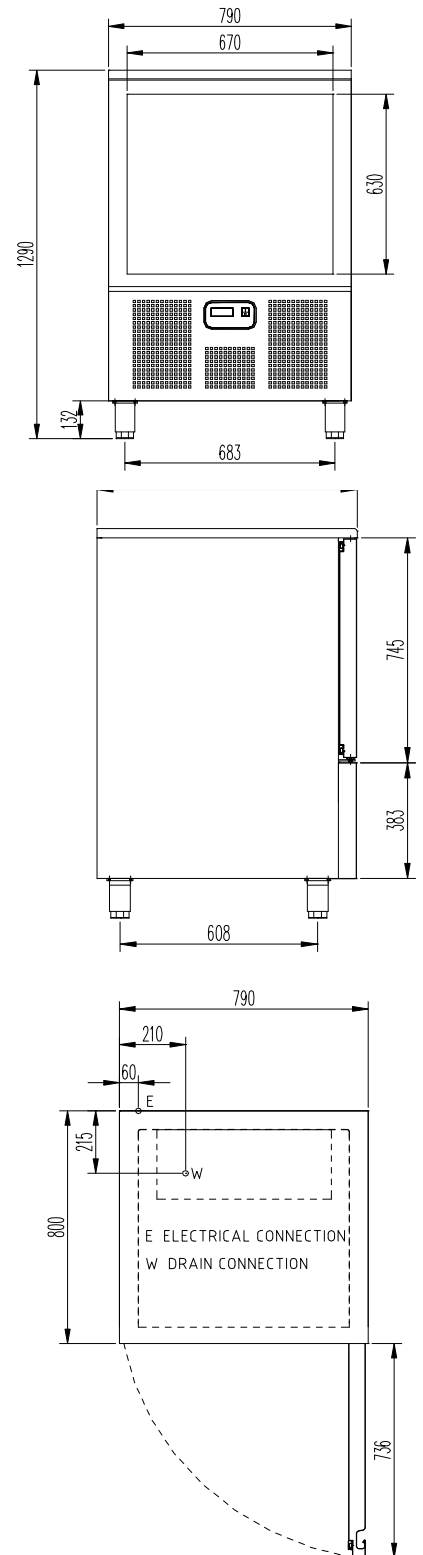

Capacidad según EN17032 (Refr, +65 °C à +10 °C en 120'; Cong +65 °C à -18 °C en 270')